

ASSEMBLY INSTRUCTION MANUAL

#60-484 COBBLESTONE SPIRAL RACK

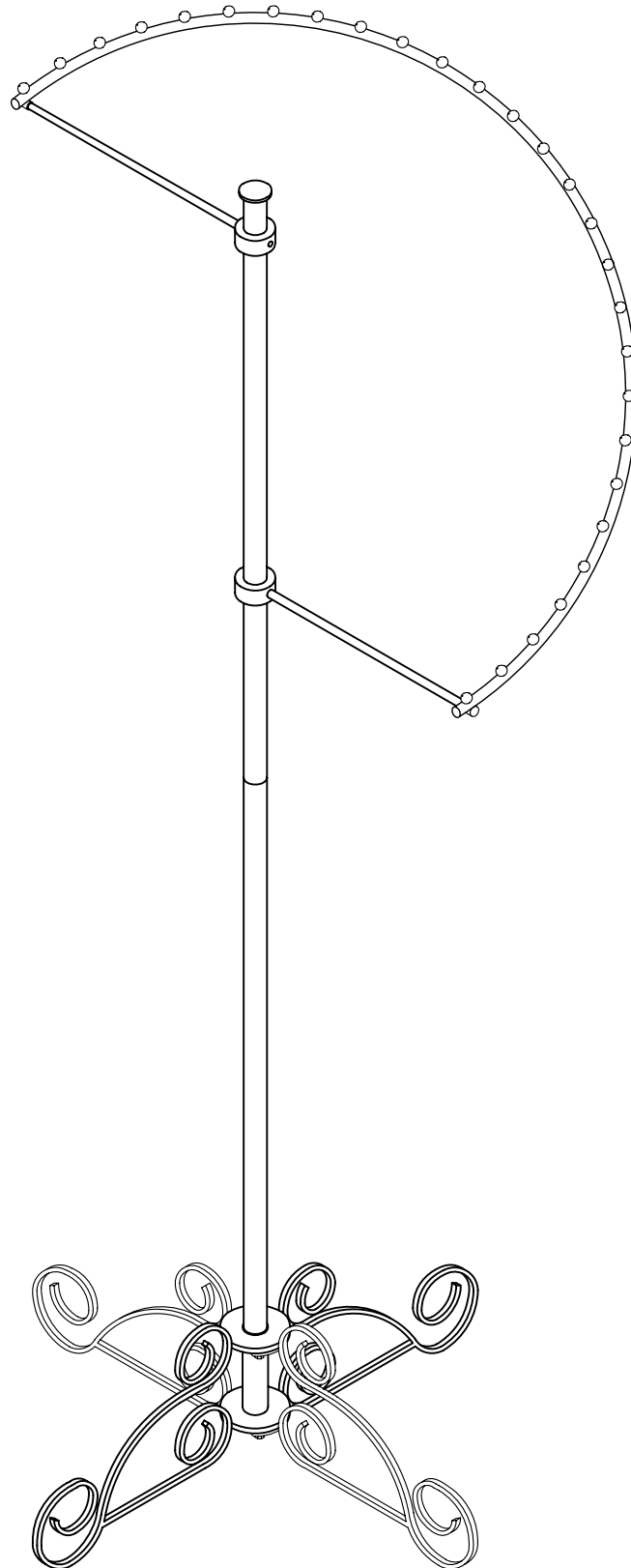

60-484 ASSEMBLY INSTRUCTION

COBBLESTONE SPIRAL RACK

PARTS IN CARTON:

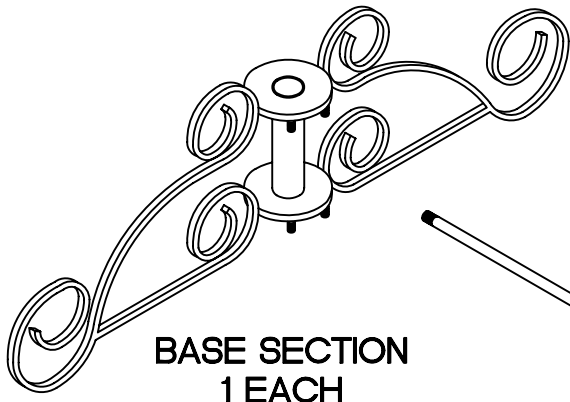

BASE SECTION
1 EACH

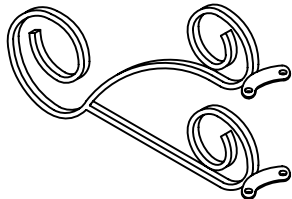

BASE BRACKETS
2 EACH

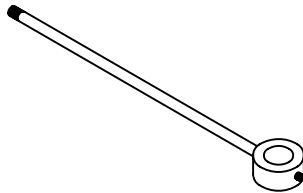

ARM BRACKETS WITH COLLAR
2 EACH



STANDARD FINIAL
SEE BELOW

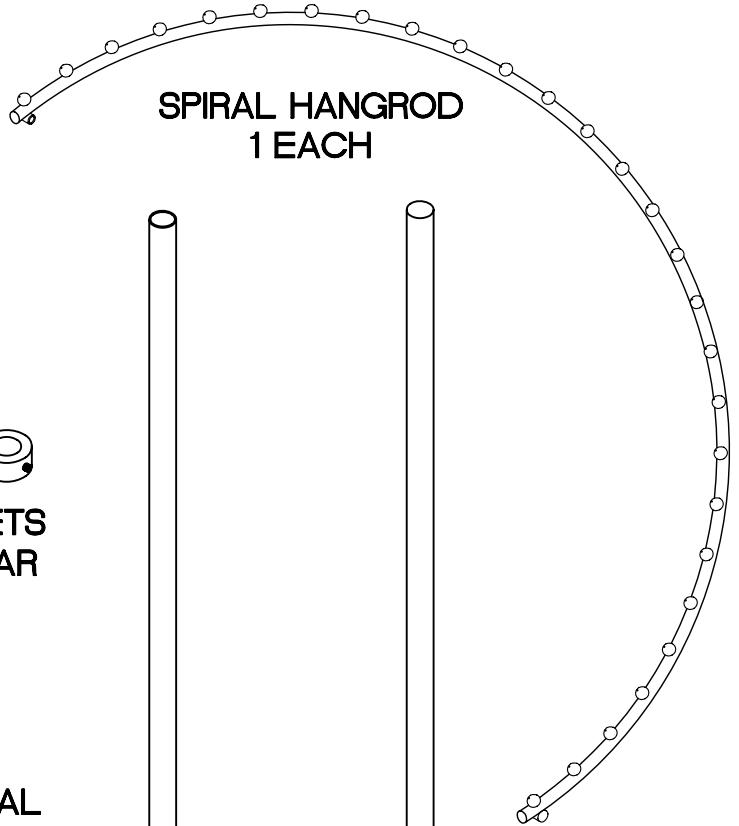

SPIRAL HANGROD
1 EACH

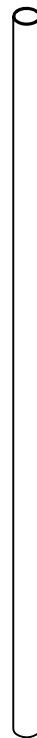

LOWER POLE
1 EACH

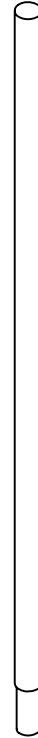

UPPER POLE
1 EACH

HARDWARE IN BAGS

NOTE: HARDWARE BELOW ARE SHOWN ACTUAL SIZE:
IF YOU ARE NOT SURE WHICH PART IS CORRECT
THEN PLACE PIECE ON TOP OF DRAWINGS FOR
HELP DURING ASSEMBLY.

HARDWARE BAG 1

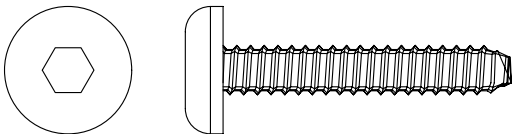

4 EACH - ALLEN HEAD BOLTS

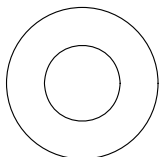

4 EACH - WASHERS



HEX-HEAD NUTS
8 EACH



SMALL ALLEN WRENCH

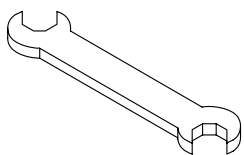

HEX-NUT WRENCH



LARGE ALLEN WRENCH

HARDWARE BAG 1

1 EACH - STANDARD FINIAL

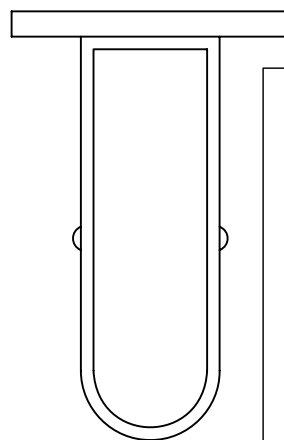

60-484 ASSEMBLY INSTRUCTION

COBBLESTONE SPIRAL RACK

ASSEMBLY STEPS:

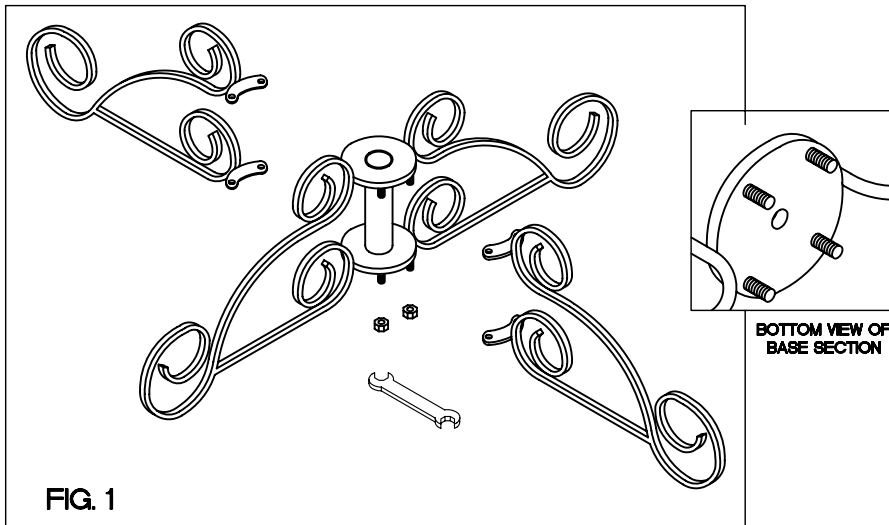

STEP 1

TAKE (1) ONE BASE SECTION AND (2) TWO BASE BRACKETS, SLIDE BRACKETS OVER THREADED STUDS OF BASE SECTION, ATTACH WITH THE (8) HEX-HEAD NUTS AND TIGHTEN WITH THE WRENCH PROVIDED. (SEE FIG. 1)

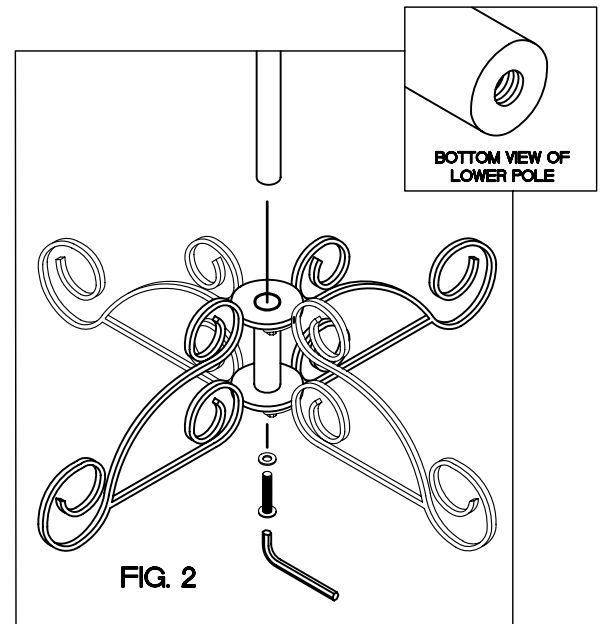

STEP 2

TAKE THE THREADED END OF THE LOWER POLE AND SLIDE INTO THE BASE SECTION. ATTACH THE POLE BY INSERTING ALLEN HEAD BOLT THRU FLAT WASHER INTO HOLE OF BASE AND SCREWING INTO BOTTOM OF POLE. TIGHTEN USING THE 1/4' ALLEN WRENCH. (LARGE ALLEN WRENCH) (SEE FIG. 2)

UNIT SHOULD NOW
LOOK LIKE THIS

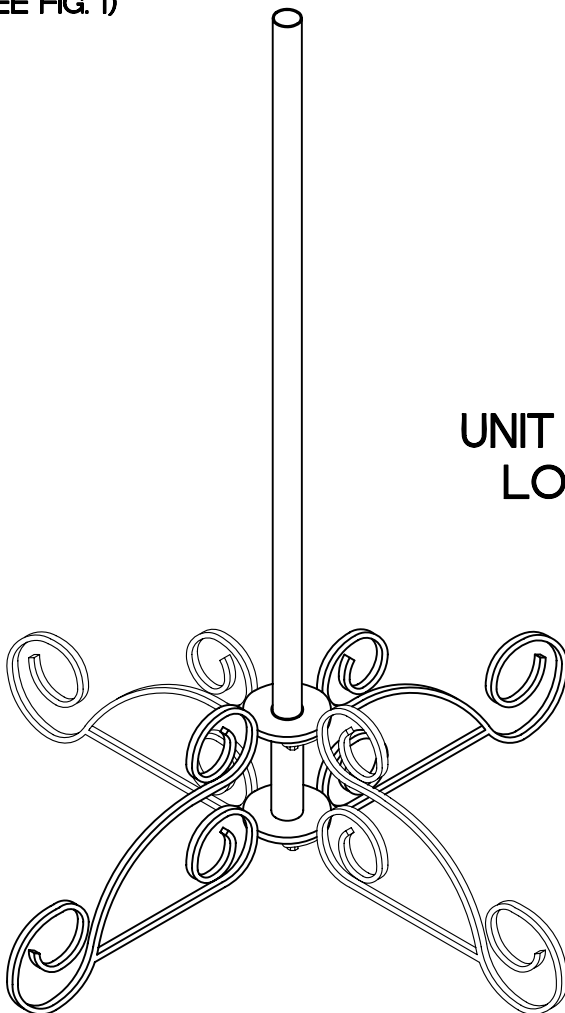

60-484 ASSEMBLY INSTRUCTION

COBBLESTONE SPIRAL RACK

ASSEMBLY STEPS CONTINUES:

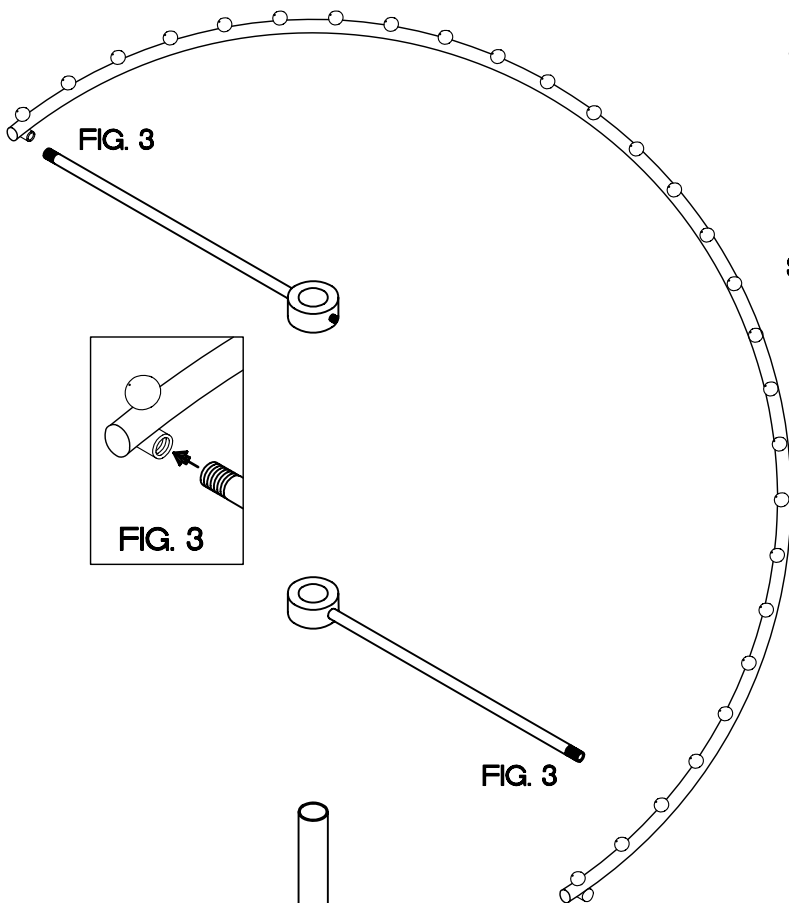

STEP 3

SCREW THE ARM BRACKETS WITH COLLAR INTO THE THREADED TUBES ON THE SPIRAL HANGROD LOCATED NEAR THE ENDS. (SEE FIG. 3)

STEP 3A

TAKE THE TAPERED END OF THE UPPER POLE AND SLIDE THROUGH THE TOP COLLAR. KEEP SLIDING THE POLE DOWN AND THROUGH THE LOWER COLLAR. NOTE! TWISTING COLLARS WILL ALLOW THE POLE TO SLIDE THROUGH UNTIL BOTH COLLARS ARE ON THE POLE.

USE THE SMALLER ALLEN WRENCH TO SCREW THE SET SCREWS TIGHTLY INTO THE POLE SO THE COLLARS DO NOT MOVE. (SEE FIG. 3A)

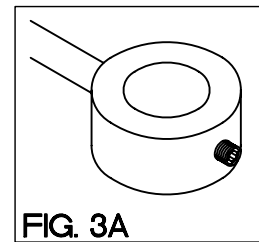

UPPER POLE

TAPERED END

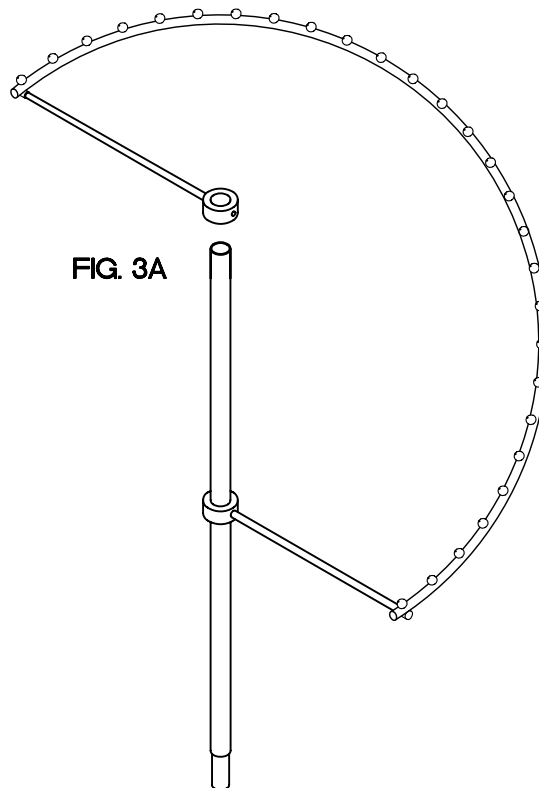

60-484 ASSEMBLY INSTRUCTION

COBBLESTONE SPIRAL RACK

ASSEMBLY STEPS CONTINUES:

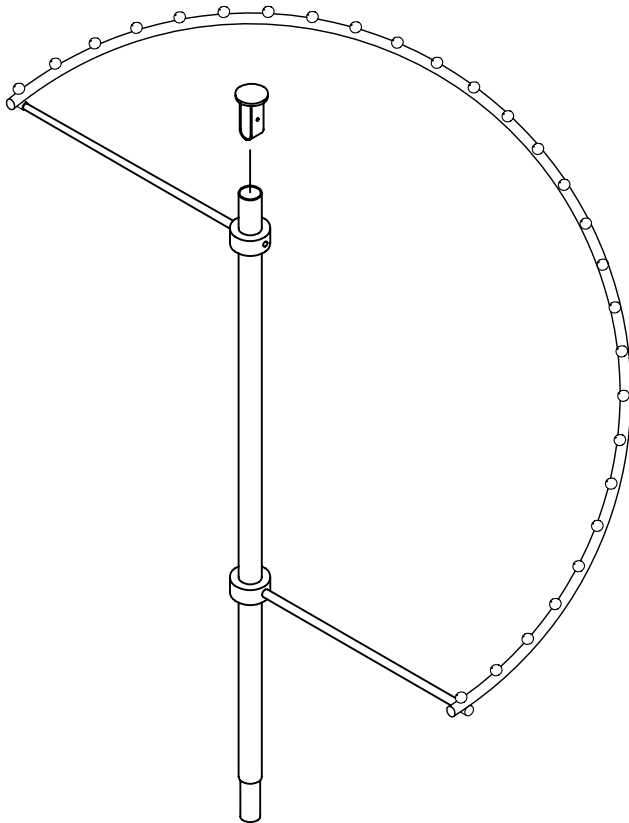

STEP 4

SLIDE THE TAPERED END OF THE POLE ON THE ASSEMBLED SPIRAL HANGROD SECTION FROM STEP 3 INTO THE LOWER POLE OF THE BASE SECTION AS SHOWN TO THE LEFT.

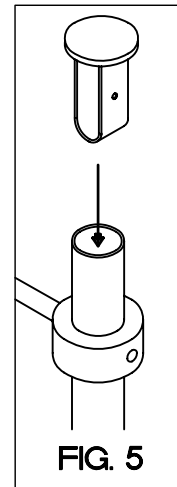

STEP 5

SLIDE THE STANDARD FINIAL INTO TOP OF UPPER POLE. (SEE FIG. 5)

ADJUSTMENT NOTE:

ADJUSTMENT OF SPIRAL HANGROD CAN BE ACHIEVED BY LOOSENING THE SET SCREW ON LOWER COLLAR, THEN BY HOLDING ONTO THE UPPER ARM AND COLLAR LOOSEN THE TOP SET SCREW AND SLIDE UP OR DOWN FOR YOUR FINAL ADJUSTMENT.

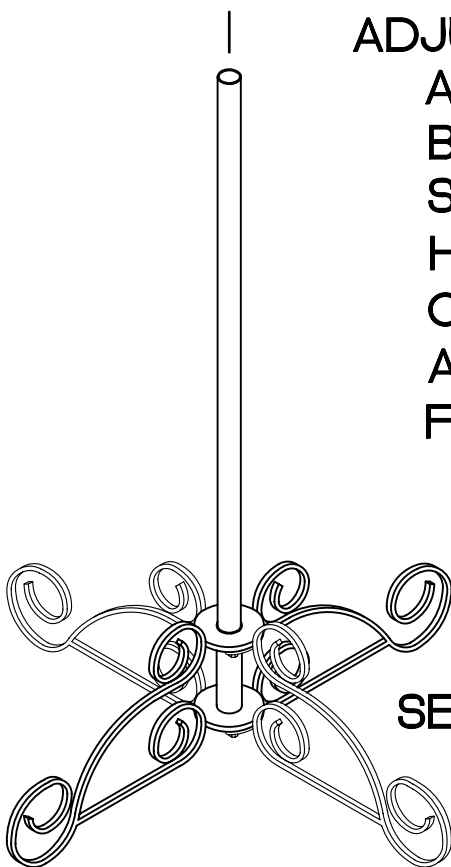

UNIT IS COMPLETE
SEE COVER FOR ASSEMBLED
FIXTURE