

ASSEMBLY INSTRUCTION MANUAL

#60-261 29 BALL SPIRAL RACK

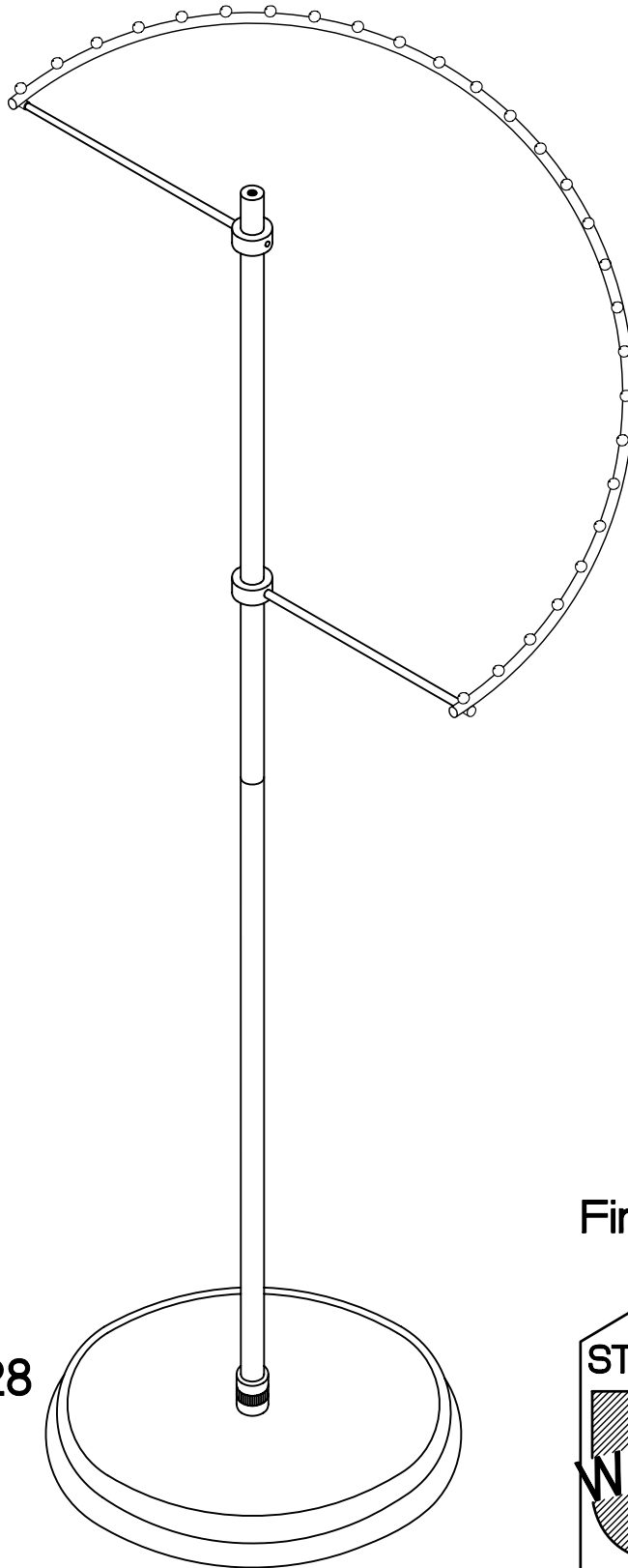

9801 PAGE AVENUE
ST. LOUIS, MO. 63132-1428
TEL: (314) 427-8887
or (800) 823-8887
FAX: (314) 427-0004
or (800) 823-0004

Final : 9/24/10



60-261 ASSEMBLY INSTRUCTION

29 BALL SPIRAL RACK

PARTS IN CARTON:

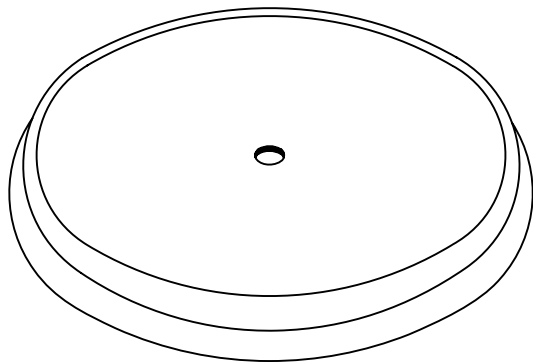

18" DIA. BASE PLATE
1 EACH

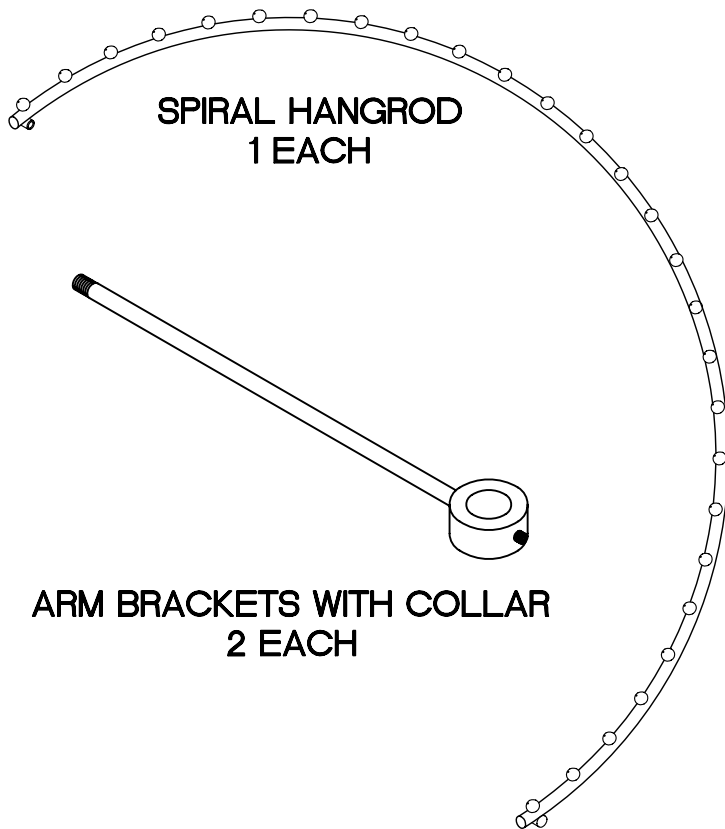

SPIRAL HANGROD
1 EACH

ARM BRACKETS WITH COLLAR
2 EACH



LOWER POLE
WITH LOCKING
COLLAR
1 EACH



UPPER POLE
WITH TAPERED
END
1 EACH

NOTE:

WRENCH IS TAPED TO THE
INSIDE BOTTOM OF BASE
PLATE.

TOOL INCLUDED (NOT ACTUAL SIZE)

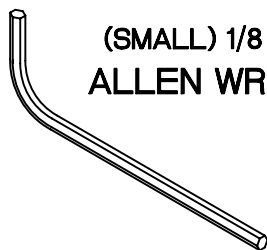

(SMALL) 1/8 INCH
ALLEN WRENCH



60-261 ASSEMBLY INSTRUCTION

29 BALL SPIRAL RACK

ASSEMBLY STEPS:

STEP 1

SCREW THE THREADED END OF LOWER POLE INTO THE 18" DIA. BASE PLATE BY HAND UNTIL COLLAR IS TIGHT AGAINST BASE PLATE.

(SEE FIG. 1 AND 1A)

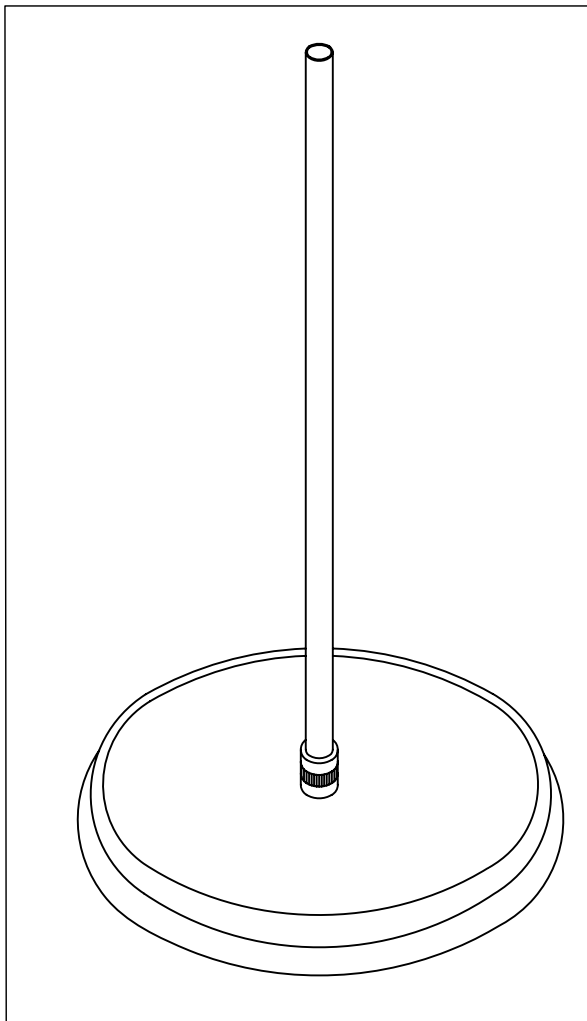
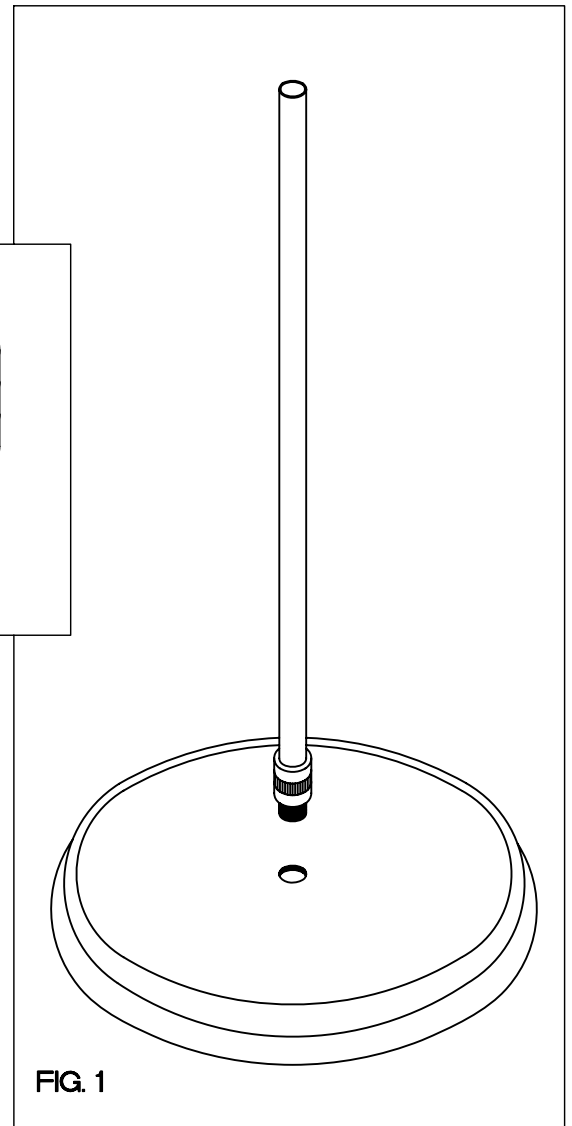
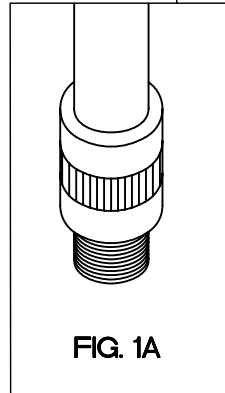

UNIT SHOULD NOW
LOOK LIKE THIS



60-261 ASSEMBLY INSTRUCTION

29 BALL SPIRAL RACK

ASSEMBLY STEPS CONTINUES:

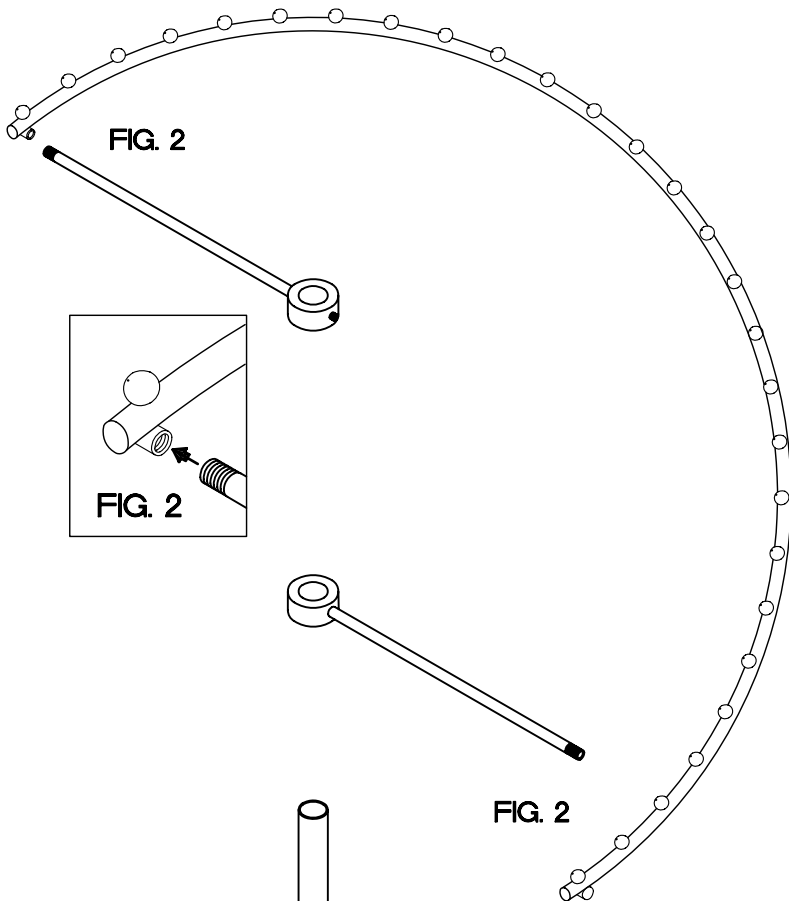

STEP 2

SCREW THE ARM BRACKETS WITH COLLAR INTO THE THREADED TUBES ON THE SPIRAL HANGROD LOCATED NEAR THE ENDS. (SEE FIG. 2)

STEP 2A

TAKE THE TAPERED END OF THE UPPER POLE AND SLIDE INTO AND THROUGH THE TOP COLLAR, KEEP SLIDING THE POLE DOWN INTO AND THROUGH THE LOWER COLLAR. NOTE: TWISTING OF THE COLLARS WILL HELP ALLOW THE POLE TO SLIDE THROUGH EASIER UNTIL BOTH COLLARS ARE ON THE POLE. USE THE ALLEN WRENCH TO SCREW THE SET SCREWS TIGHTLY INTO THE POLE SO THAT COLLARS DO NOT MOVE. (SEE FIG. 2A)

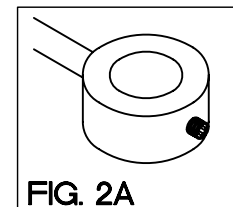
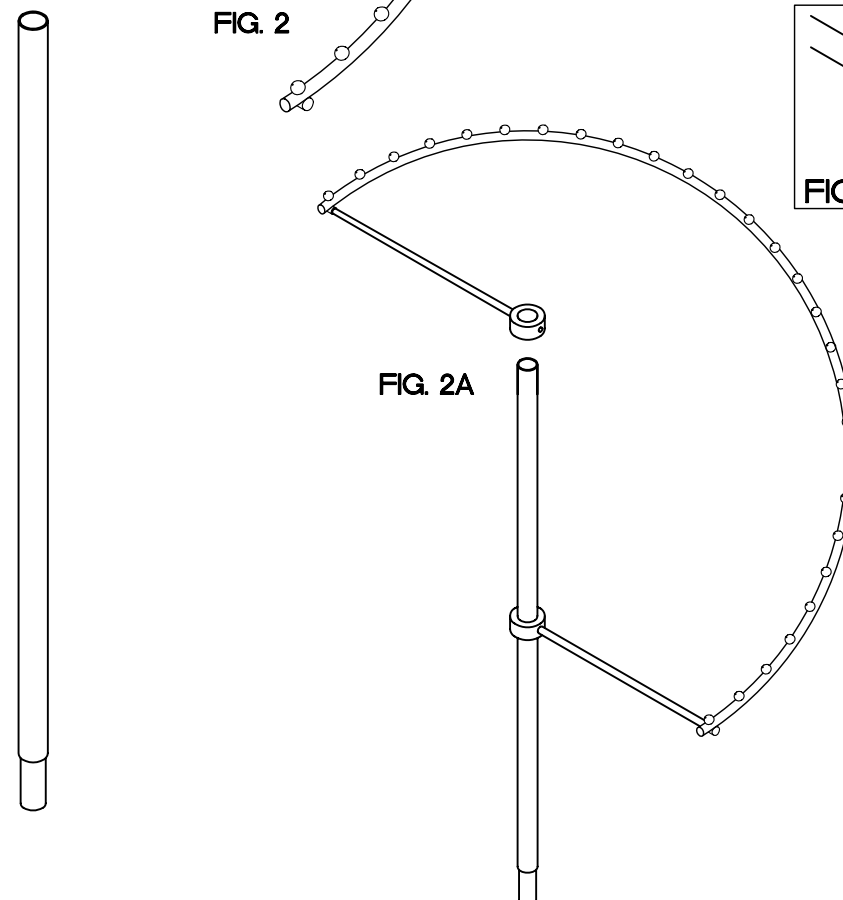

UPPER POLE

TAPERED
END



60-261 ASSEMBLY INSTRUCTION

29 BALL SPIRAL RACK

ASSEMBLY STEPS CONTINUES:

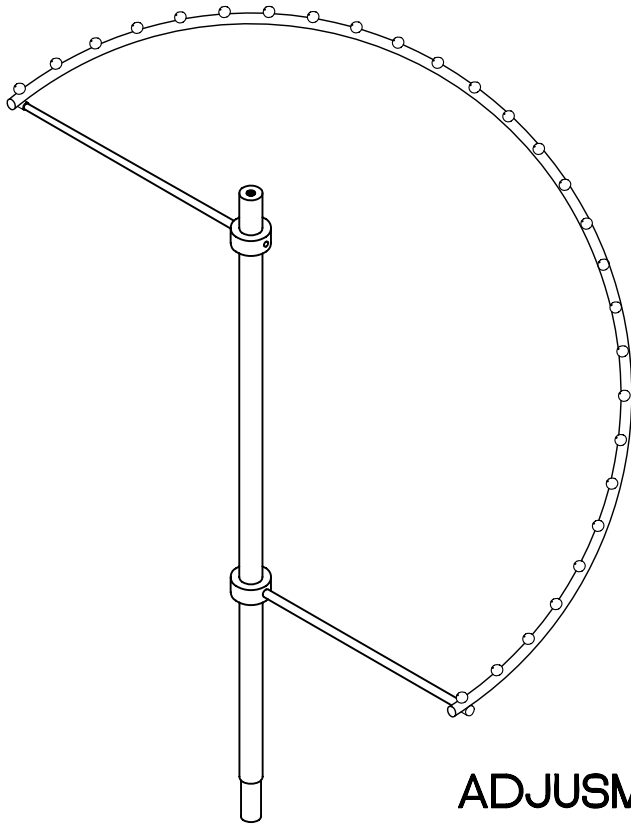

STEP 3

SLIDE THE TAPERED END OF THE POLE ON THE ASSEMBLED SPIRAL HANGROD SECTION FROM STEP 2 INTO THE LOWER POLE OF THE BASE SECTION AS SHOWN TO THE LEFT.

ADJUSTMENT NOTE:

ADJUSTMENT OF SPIRAL HANGROD CAN BE ACHIEVED BY LOOSENING THE SET SCREW ON LOWER COLLAR. THEN BY HOLDING ONTO THE UPPER ARM AND COLLAR LOOSEN THE TOP SET SCREW AND SLIDE UP OR DOWN FOR YOUR FINAL ADJUSTMENT.

UNIT IS COMPLETE
SEE COVER FOR ASSEMBLED FIXTURE

